

Industrial Routing Switch

RFI-18-F16

- ⌘ High performance and configurable
 - 16 fibre ports
 - Flexible SFP transceiver design
 - Advanced WeOS layer 3 functionality
- ⌘ Designed for use in harsh industrial applications
 - Dual 16 – 60VDC power input
 - Highly configurable fault I/O contact
 - Robust aluminium housing
- ⌘ Robust for long service life
 - 520,000 hours MTBF to MIL-HDBK-217K
 - –40 to +70°C (–40 to +158°F) with no moving parts
 - Industrial EMC, shock and vibration testing
- ⌘ Unique future proof industrial networking solutions
 - Simple web configuration with professional CLI
 - Network IP Security and remote access
 - Multiple network resilience solutions



RedFox is designed for industrial application with many functions designed for easy use. The high bandwidth design allows for up to 8 Gbit ports as well as having other ports that can deliver 10/100 Mbit. The RedFox is powered by WeOS (Westermo Operating System) which is our cross platform solution providing strong future proofing and ease of use.

In RedFox the design of the electronics is critical to ensure long service life in extreme operating environments. Only industrial grade components are used which gives the RedFox an MTBF of 520 000 hours. The ultra robust RedFox has a heavy-duty aluminium enclosure for maximum strength and heat dissipation ensuring that the wide temperature range –40 to +70°C (–40 to +158°F) can be achieved with no moving parts or cooling holes in the case.

RedFox has been tested both by Westermo and external test houses to meet many EMC, isolation, vibration and shock tests, all to the highest levels suitable for heavy industrial environments and rail trackside application.

WeOS is a Layer 3 switch operating system that can deliver unique IP security functionality for this class of product, for instance a Multiport DMZ can be constructed by utilising the internal port based firewall function. Remote secure access to a network can be provided using encrypted VPNs. For more WeOS functionality please see the WeOS datasheet.

Ordering Information

Art.no	Description
3641-3420	RFI-18-F16, 2 ports 10/100BaseT and 16 SFP slots for 100Base FX
1211-2027	CLI Cable (Console), (Accessories)
3125-0001	PS-30, Power supply, DIN mounted (Accessories)

Specifications RFI-18-F16

Dimensional drawing

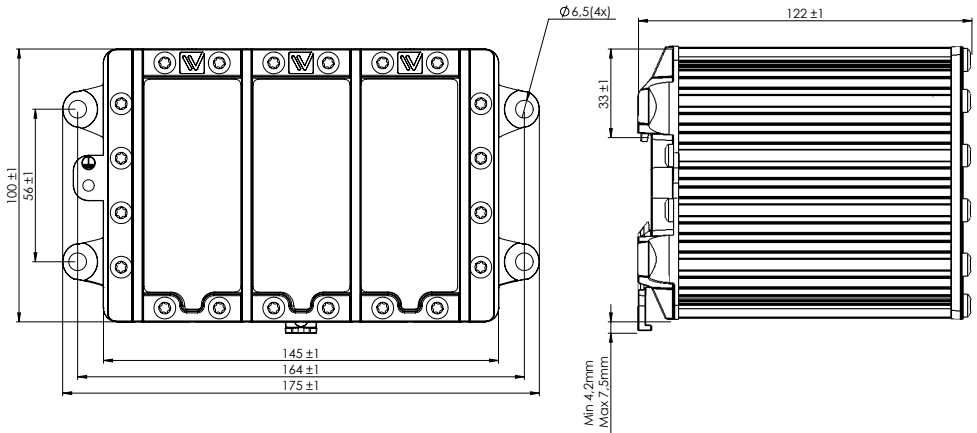

Dimension 175 × 100 × 122 mm (6.88 × 3.93 × 4.80 in)
 Weight 2.2 kg
 Degree of protection IP 40

Power

Operating voltage	16 to 60 VDC
Rated current	1110 mA @ 20VDC

Interfaces

Console	1 × 2.5 mm jack, use Westermo cable 1211-2027
USB	1 × USB 2.0 host interface
Digital I/O	1 × 4-position detachable screw terminal
Ethernet TX	2 × RJ-45, 10 Mbit/s or 100 Mbit/s
Ethernet SFP	16 × SFP, 100 Mbit

Temperature

Operating	-40 to +70°C (-40 to +158°F)
Storage & Transport	-40 to +85°C (-40 to +185°F)

Agency approvals and standards compliance

EMC	EN 55024, EN 55024 A1, EN 55024 A2, Electromagnetic compatibility – Immunity IT equipment
	EN 55022, EN 55022 A1, Information technology equipment. Radio disturbance characteristics. Limits and methods of measurement
	EN 61000-6-2, Electromagnetic compatibility – Immunity for industrial environments
	EN 61000-6-4, Electromagnetic compatibility – Emission for industrial environments
	EN 50121-4, Railway applications – Electromagnetic compatibility – Emission and immunity of the signalling and telecommunications apparatus
	FCC part 15 Class A
Safety	EN 60950-1, IT equipment